

SYNARE 3 REPAIR MANUAL



INTRODUCTION.

Synare 3 is a battery powered, stick activated, electronic drum that functions like a keyboard synthesizer.

The strike of a drum stick connects the batteries to the voicing circuitry and activates the envelopes. These two actions result in the production of a sound in accordance with the settings of the front panel controls.

NOTE: Before repairing a faulty unit it would be wise to do two things: 1. go through the instruction manual using a good unit; 2. go through the repair manual with a good unit.

COMMON PROBLEMS.

Description. Most problems that occur in Synare 3 can be fixed without the use of schematics. These problems result from two sources: worn-out batteries and careless use.

Worn-out batteries. Most Synare 3s returned for repair simply have worn-out batteries. Worn-out batteries can manifest themselves in many surprising ways - by pitch drift, frequency modulation, distortion, no sound production, etc. Therefore, always test a unit with fresh batteries and request that units sent back for repair include the batteries.

Careless use. No one plays harder than a drummer. This some times results in broken pot shafts, switch handles, loose pot nuts, broken battery snaps and broken wires.

A third less common class of problems is represented by those units that are intermittent or "crackle" when played. These result from cold solder joints which can be visually detected and faulty pots or switches.

Testing. Begin by listening to the returned unit using fresh alkaline batteries. If the unit does not respond, check for broken wires or faulty battery snaps. If the unit still does not respond or responds poorly, visually check for cold solder joints.

If this fails to uncover anything, gently pry the knobs off the pot shafts using a screw driver. Remove the nine nuts holding the pots to the hood. Inspect the back of each pot for broken pots.

All of the above problems can usually be solved without having to look at the schematics and represent the vast majority of Synare 3 problems.

SCHEMATICS.

Eight circuits are used to produce the sound that results from the striking of the playing surface: 1. battery saver circuit, 2. regulators, 3. noise generator, 4. oscillators, 5. voltage controlled filter, 6. filter control, 7. voltage controlled amplifier, 8. envelope generators.

BATTERY SAVER CIRCUIT.

Description. This circuit disconnects the batteries from all remaining circuits 10-20 seconds after the last strike on the playing surface. Its purpose is to extend battery life.

BATTERY SAVER CIRCUIT.

Description. (continued)

A speaker is used as a transducer to detect strikes. The voltage produced by the speaker coil's motion is applied to a transistor amplifier. The output of this amplifier goes to the envelope generators and a one shot used to switch the battery voltage to the regulators.

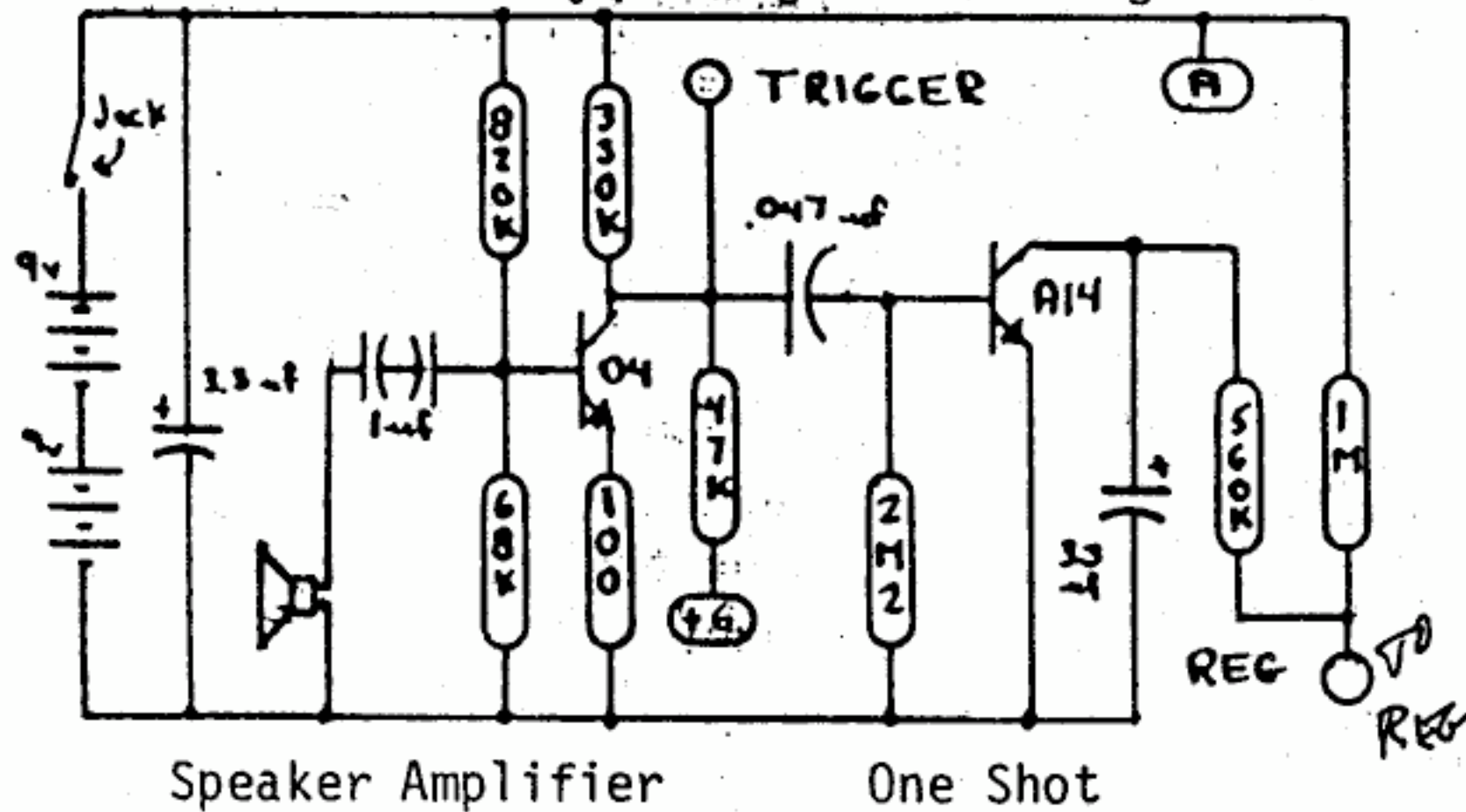

Testing. Install the batteries and put a phone plug into the unit. The phone plug switches the battery voltage to the battery saver circuit. With fresh batteries the voltage at point "A" should measure 16-20 volts using battery minus as ground. (The black wired speaker terminal is a convenient place to pickup battery minus.) If the battery voltage is not present, check the battery snaps or the switching jack for function. If the voltage is present, tap the speaker coil with a screw driver to simulate the playing pad being struck. Simultaneously check to see if the collectors of the 2n3906s have jumped to battery voltage. If so, move on. If not, check the circuitry of the b.s.c. for function. Note that this voltage will disappear after 10-20 seconds.

REGULATORS.

Description. This circuit provides regulated voltage to all the voicing circuits for 10-20 seconds beginning at the instant the playing pad is struck.

The one shot of the b.s.c. is connected to a pair of PNP transistors wired in a darlington configuration. This pair switches battery voltage to the regulators.

The two regulators produce 12 and 6.2 volts from the batteries 16-20 volts. The 6.2 volt regulator is used as an imaginary ground. Ground from all external equipment is connected to it.

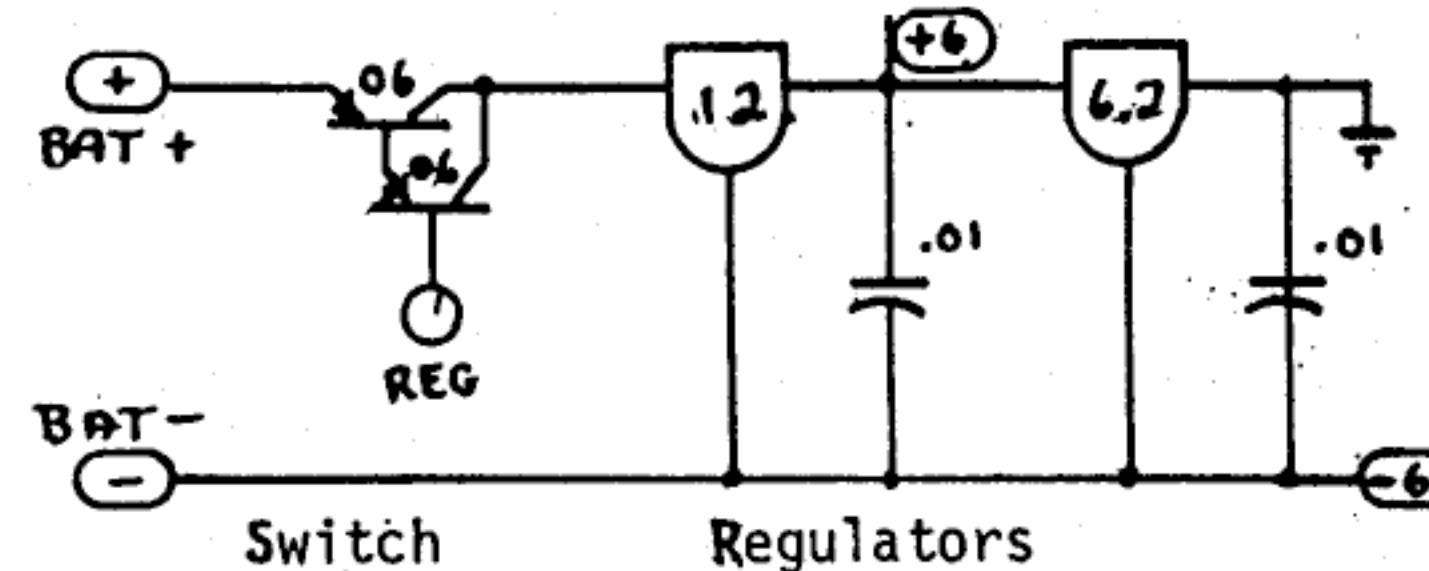

Testing. Check to see if the regulators are producing the proper output voltages. For the remaining measurements it is useful to use the imaginary ground as a scope reference. This can be picked up at the terminal of the jack with a black wire on it.

NOISE GENERATOR.

Description. The noise generator consists of a selected transistor whose base to emitter junction is used as a zener noise source. The output of the noise source is amplified by a single transistor amplifier.

NOISE GENERATOR.

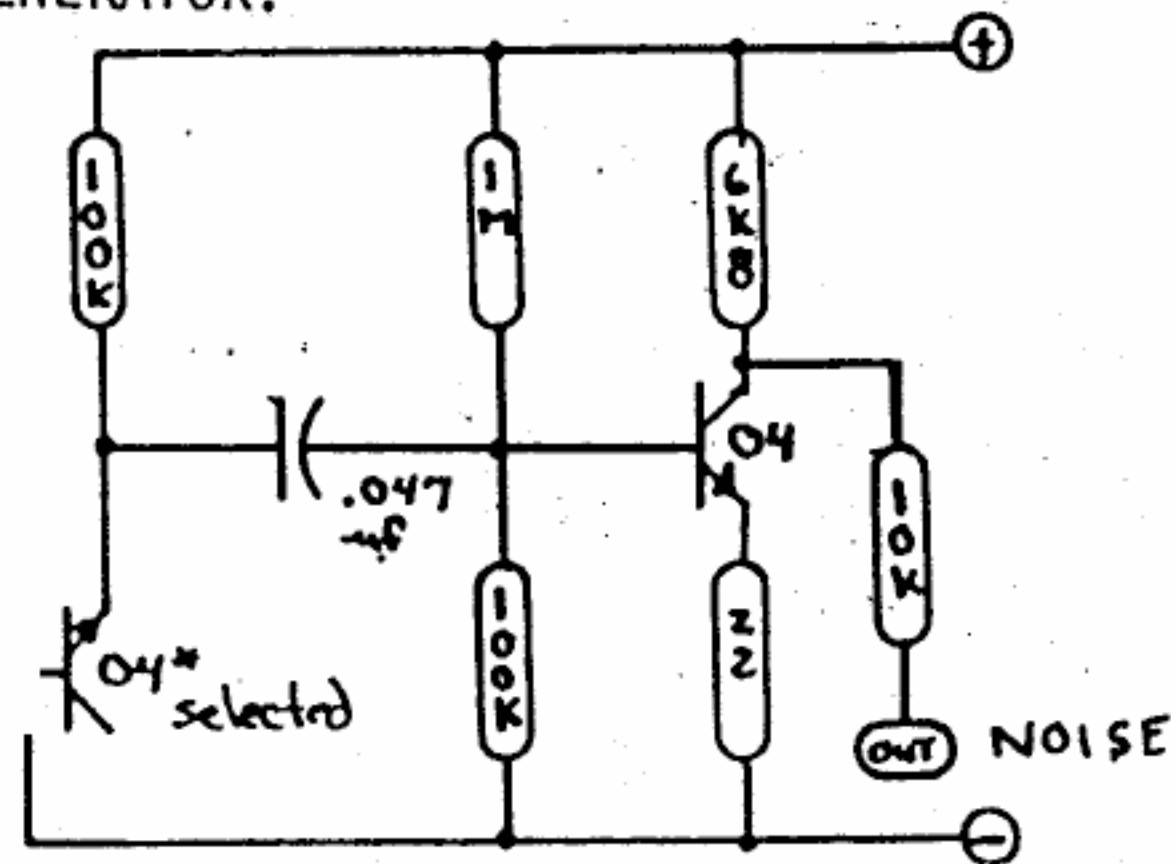

Source Amplifier

Testing. Noise can be checked at the output of this circuit. (Don't forget to tap the speaker to turn the power on.) Most noise problems consist of insufficient amplitude or modulation on the noise. They can be fixed by replacing the noise source.

OSCILLATORS.

Description. The two oscillators are generated by a CMOS 4093. The 4093 contains four 2 input nand gates with Schmidt trigger inputs. Two of the four sections are used to form oscillators.

Osc 1 is a single inverting schmidt trigger wired as a dual slope integrating oscillator. A square wave is available at its output. The frequency of this oscillator is variable from 40 to 1500Hz.

Osc 2 is identical to Osc 1 except for two abilities: 1. it is range switchable, and 2. a triangle output is available.

Range switching is achieved by increasing the

OSCILLATORS.

Description. (continued)

size of the integrating capacitor. The triangle is derived from the integrating capacitor at the input. This point is buffered by a darlington emitter follower. The triangle output is used as a filter control voltage.

The square wave outputs of the oscillators are used as audio inputs to the filter when their selector switches are pushed to the right.

The center position of Osc 1's switch inputs noise to the filter. The center position of Osc 2's switch reduces the frequency of Osc 2 by a factor of 20.

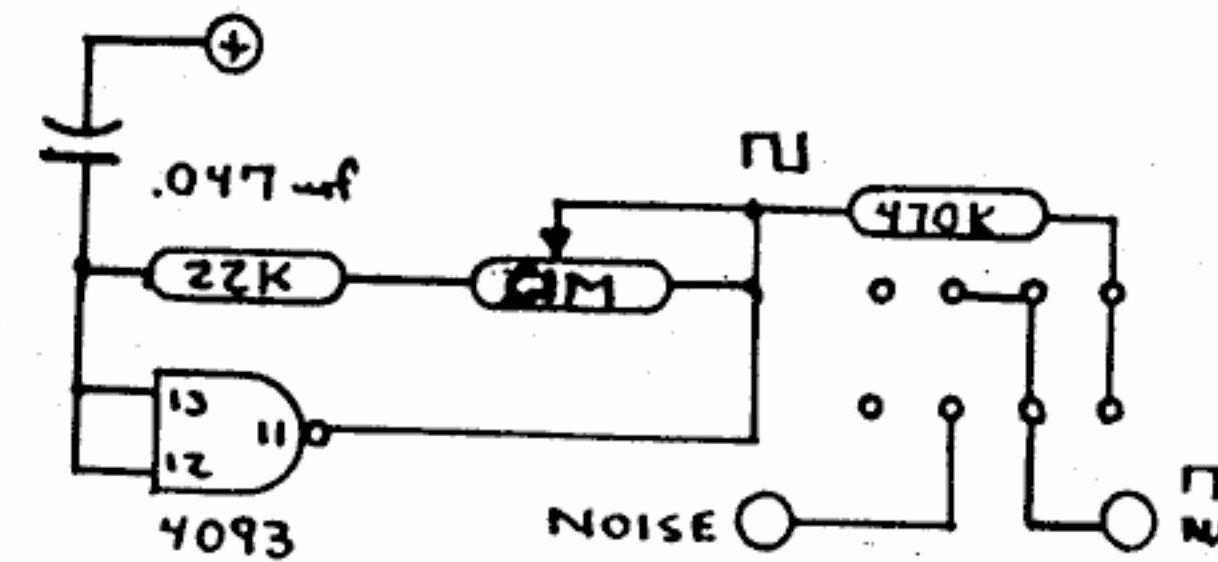

Oscillator 1

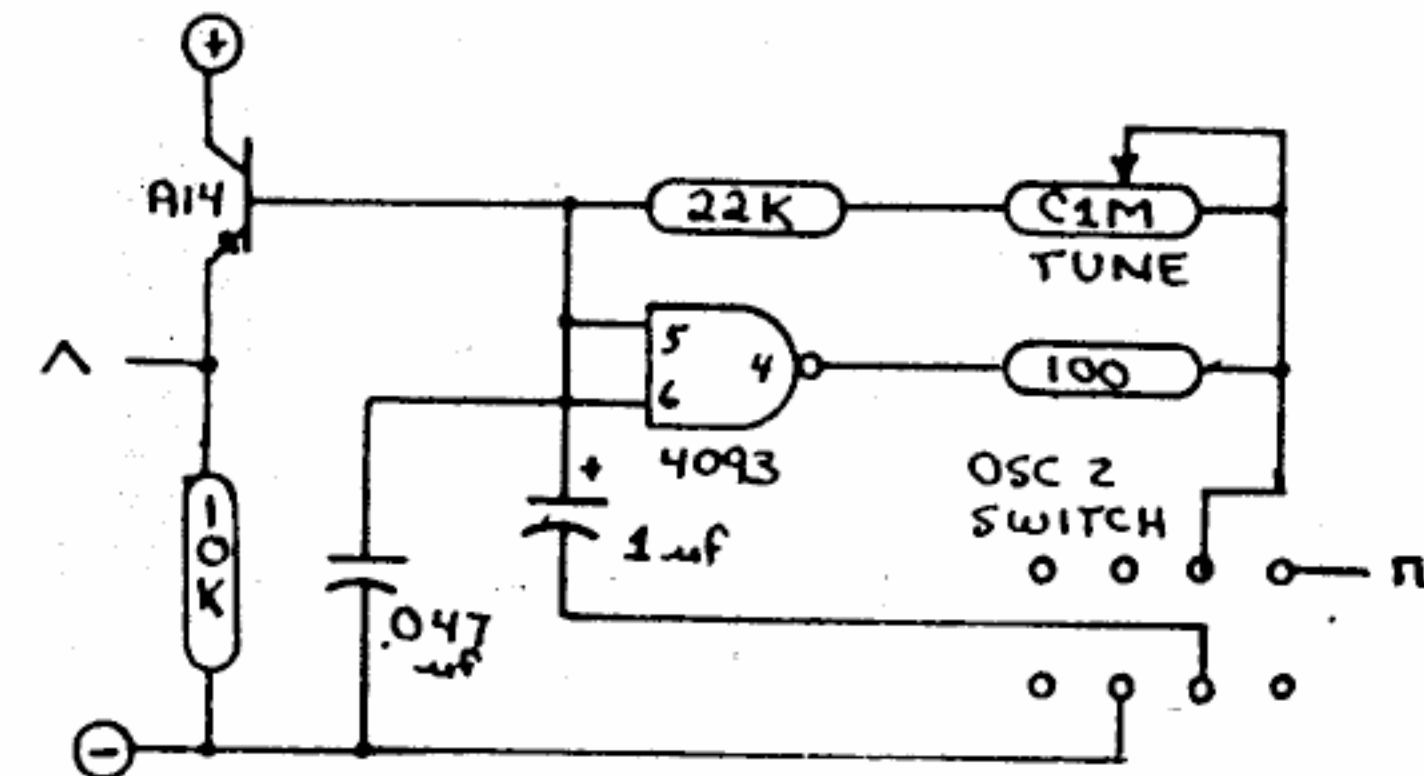

Oscillator 2

OSCILLATORS.

Testing. The output of the oscillators can be measured at the 4093, tuning pots, or the input to the filter. Common problems are broken switches, pots, and rarely, a bad 4093. (Note that only RCA 4093s work well in this circuit.) It is also normal for the triangle output to appear clipped until the filter's Osc 2 pot is turned up.

FILTER.

Description. The four pole, low pass voltage controlled filter is the dominant portion of the Synare 3. It can be used as a sine wave oscillator or as a timbre modifier of the oscillators and noise generator.

The filter is composed of four voltage controlled integrators. Each integrator is a transconductance amplifier (3080) followed by a darlington emitter follower. The fourth stage is fed back to the first through the resonance pot to permit adjustment of the filter's "Q". (Only two of the four stages are shown below.)

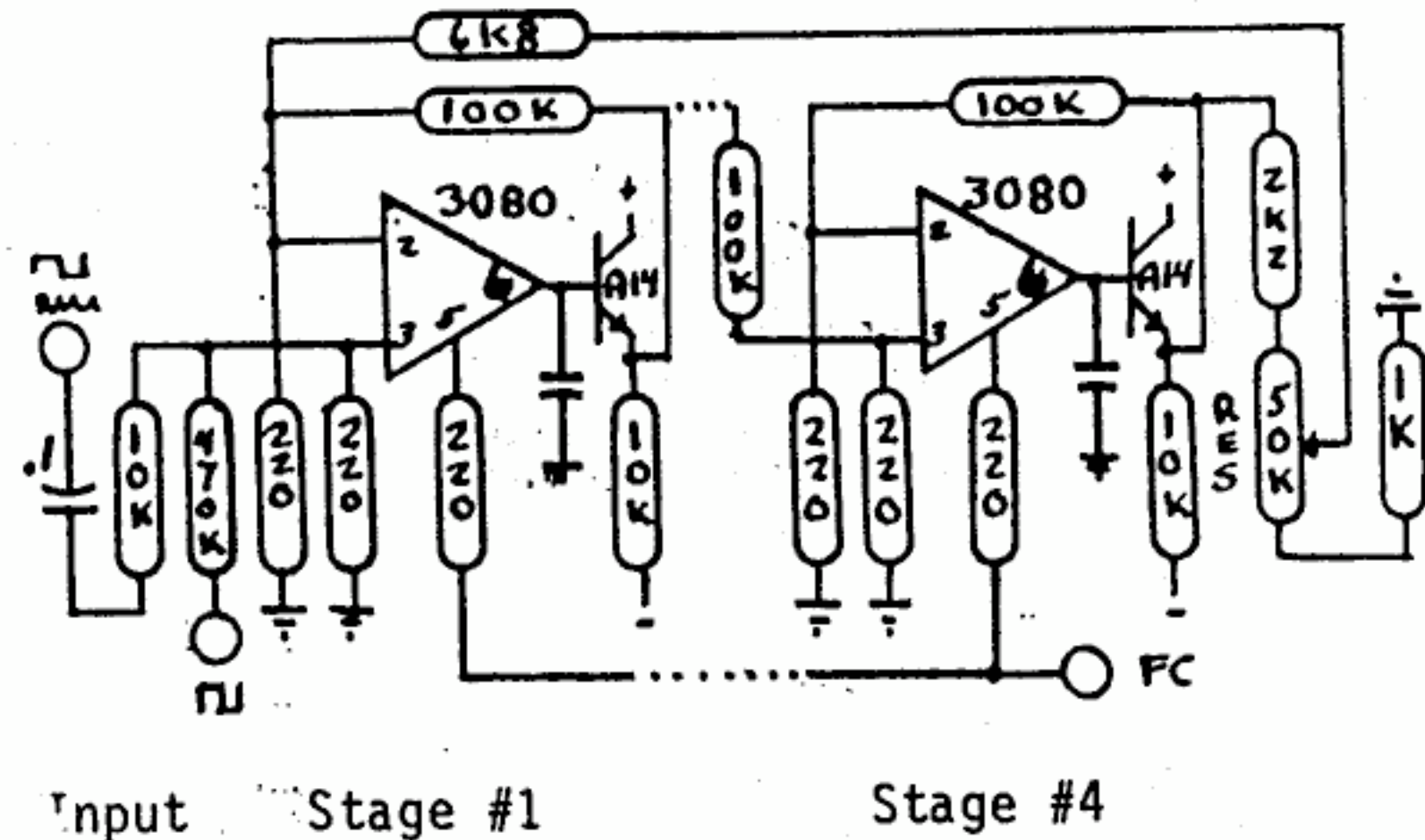

FILTER.

Testing. It is easiest to test the filter with the resonance turned to zero (non-oscillating mode). Input Osc 1 to the filter and turn up the filter tune. The fourth stage of the filter should now be passing Osc 1. If not, beginning with the first stage, check the emitter of each darlington emitter follower for the presence of Osc 1. This should easily point out the faulty filter stage.

Testing of the filter as an oscillator will be covered in the next section.

FILTER CONTROL.

Description. The filter control circuit tunes the filter's cutoff frequency by controlling the integrating current of all four filter sections.

The circuitry consists of a simple resistor mixer followed by a current generator.

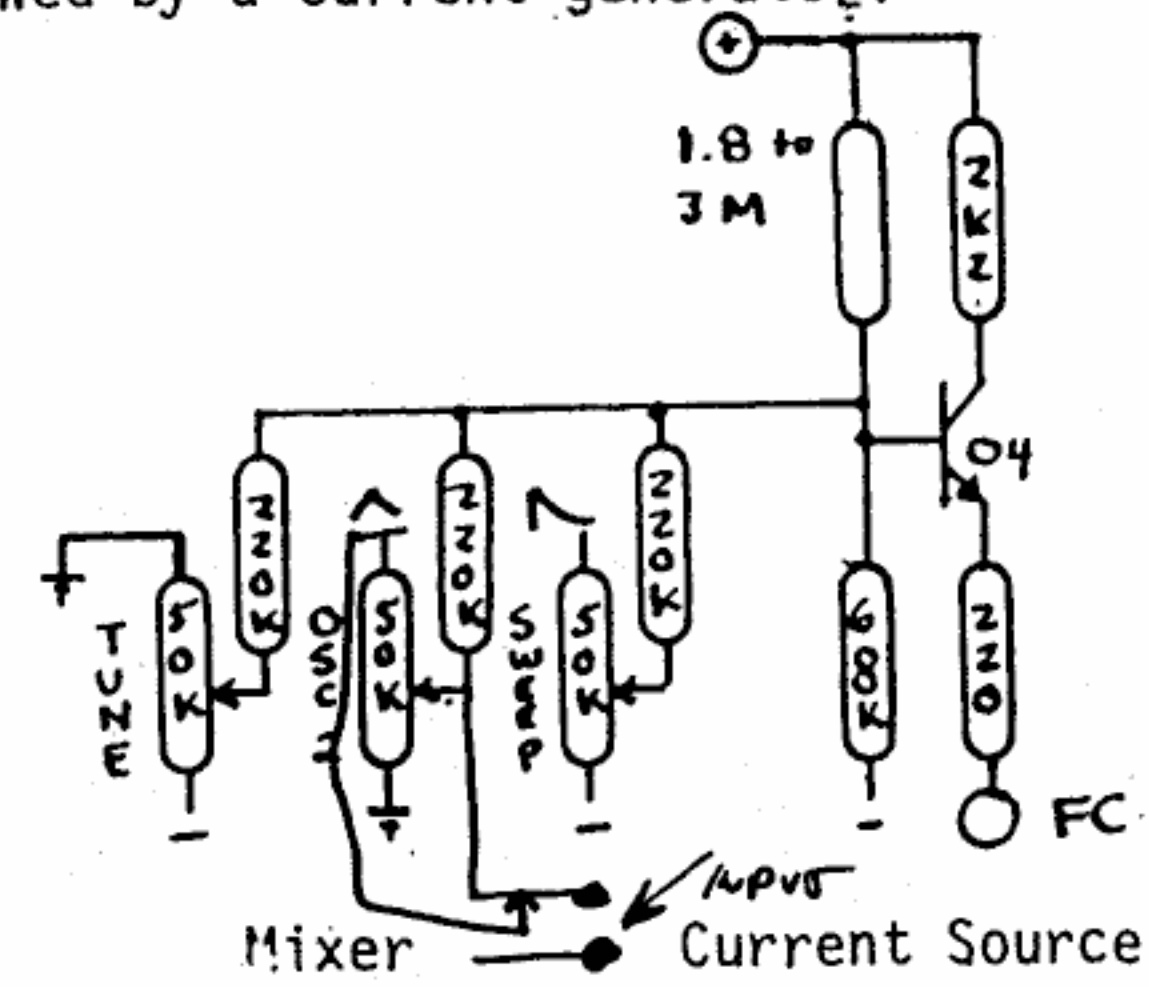

Testing. The easiest way to test this circuit is to have the filter in its oscillating mode

FILTER. CONTROL.

Testing. (continued)

and to see if the filter responds properly to its control voltages.

To use the filter as an oscillator the selector switches should be off and the resonance turned up full.

The filter has three panel controls that effect filter tuning - filter tune, filter Osc 2 (application of triangle wave), and filter sweep (filter envelope).

The filter tune control is capable of moving the filter from 30Hz to 4KHz. The bottom end (30Hz) is adjusted at the factory by selecting a resistor that normally ranges from 2 to 3 megs.

The filter's Osc 2 control adds frequency modulation or vibrato to the filter. The speed of modulation is determined by Osc 2's tune control. and selector switch.

The sweep control causes the filter pitch to instantly jump up on a pad strike and then to glide back down. The time of the glide is set by the filter's decay control.

Problems in this area are usually caused by faulty pots.

AMPLIFIERS.

Description. The voltage controlled amplifier consists of a transconductance amplifier (3080) used as a two quadrant multiplier. Its audio input comes from the filter and its control input is the combination of the outputs of two envelope generators. The output of the 3080 drives the volume pot and the output jack.

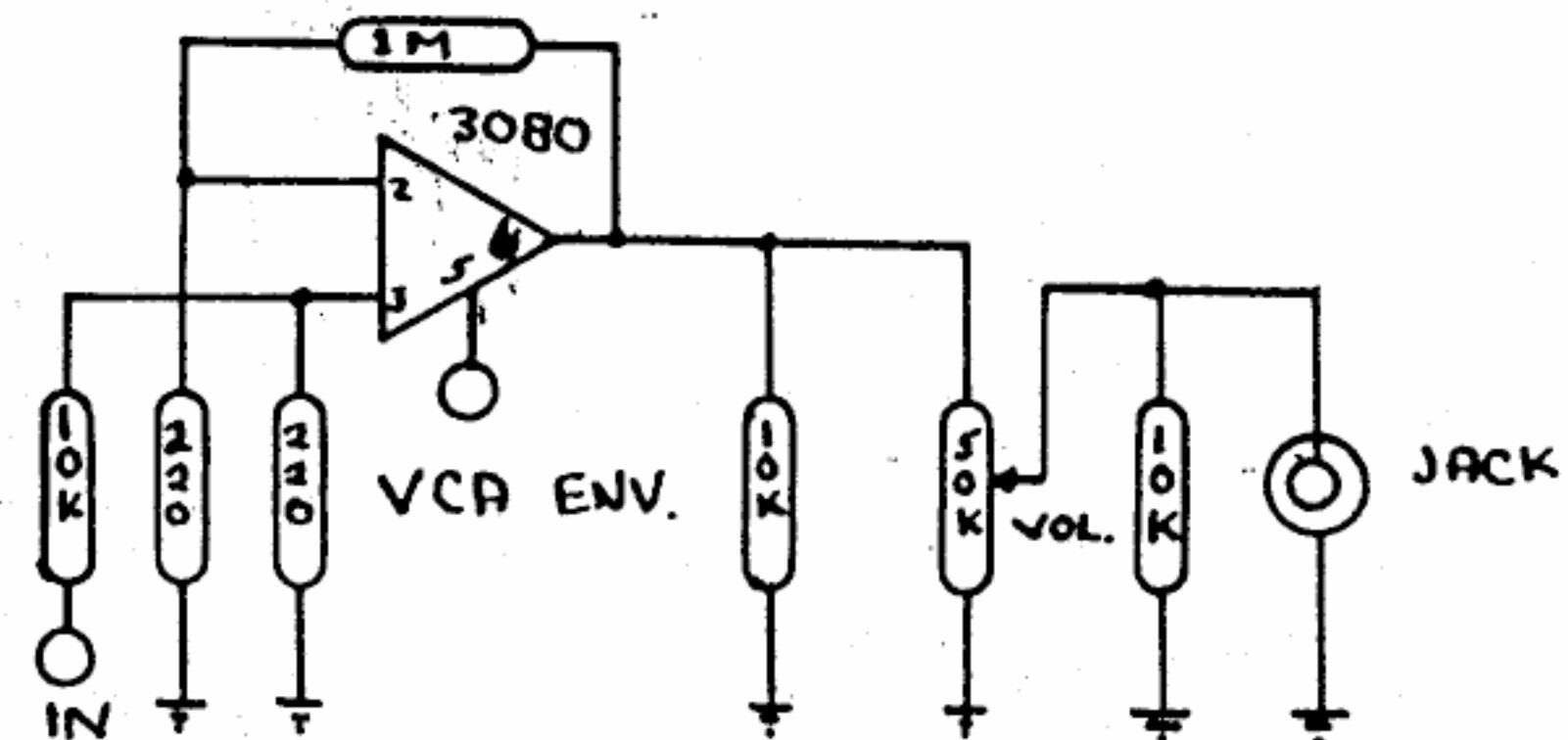

Voltage Controlled Amplifier

Testing. The output of the amplifier may be conveniently tested at the volume pot or output jack. There is rarely a problem with the 3080s. In general, suspect the envelope generators.

ENVELOPE GENERATORS.

Description. There are three envelopes in Synare 3. The envelopes are initiated by a strike on the playing pad. The output of the speaker amplifier in the b.s.c. is applied to three 04s each connected in an emitter follower configuration with large capacitors in their emitters.

The strike charges each capacitor to the base voltage. (The base voltage is proportional to

ENVELOPE GENERATORS.

Description. (continued)

the strike force.) The capacitors each discharge at a rate determined by their bleed resistors. Two envelopes have variable bleed resistors which are variable from panel controls labelled filter and amplifier decay. Both variable envelopes are followed by emitter followers.

The third envelope has a fixed bleed resistor. It bleeds through the voltage controlled amplifiers together with one of the variable envelopes. The other variable envelope (filter decay) is used as a filter control voltage to produce sweep.

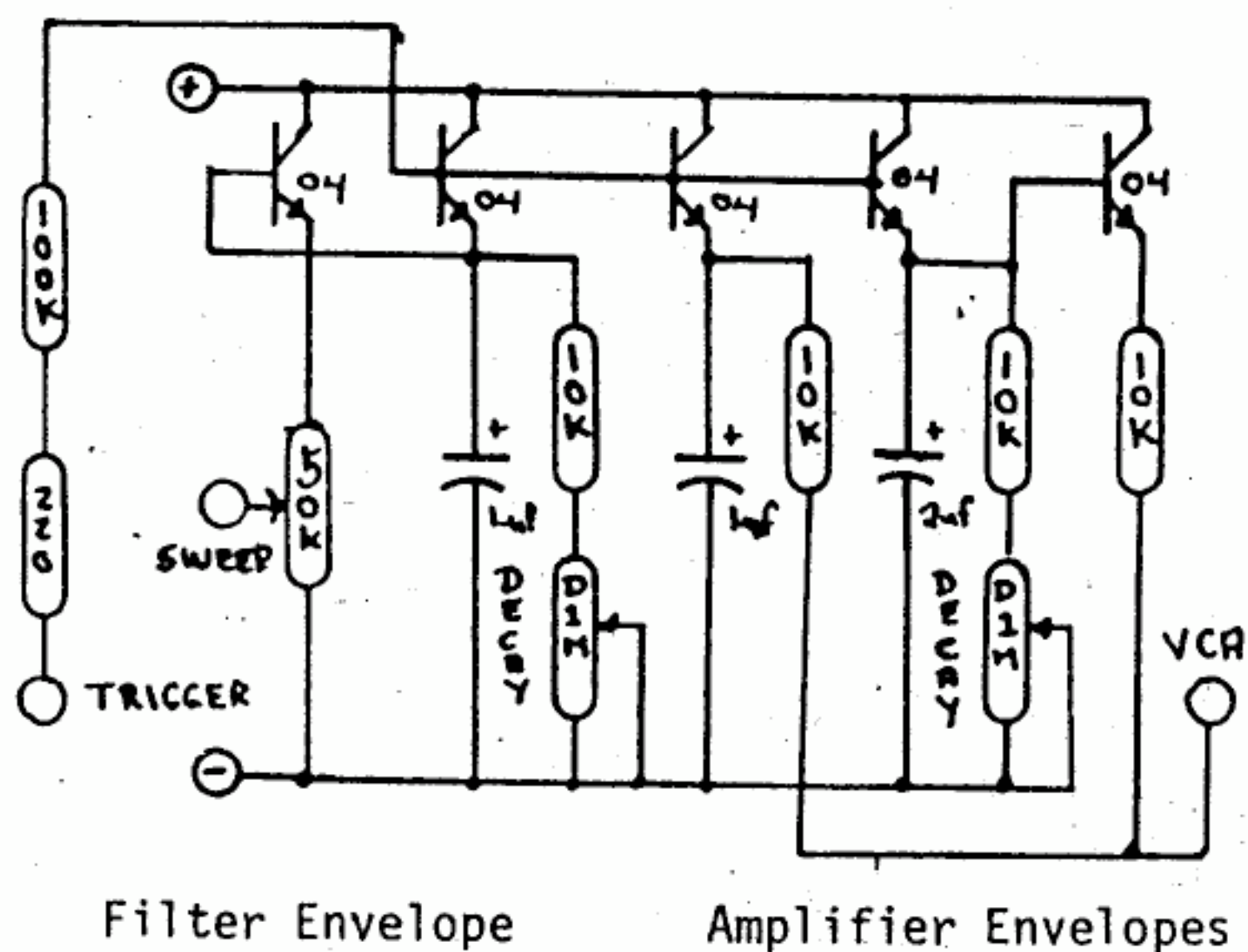

Testing. The envelopes are difficult to trouble shoot because of their common base connection. A failure at one base looks like a failure at all. The easiest thing to do is to replace all three 04s.

MODIFICATIONS.

Any modification to a Synare 3 not done by the factory or authorized by the factory voids the warranty. The following group of potential modifications IS NOT authorization to do modifications.

External Power. The Synare 3 requires 20 volts at 25 ma when being played. Power can be applied through the 5 pin connector on the component side of the board or hardwired. (A description of the connector can be found in the section labelled TESTER.) Hardwiring consists of connecting supply plus to either end of the red twisted pair and supply minus to speaker minus (the black wire).

The use of external power will add hum to the output unless the source is well filtered.

Reduced Oscillator Range. The high end of the oscillators can be decreased in frequency by increasing the 22K resistor in series with each pot.

The low end can be increased by decreasing the .047 integrating capacitor. This will also increase the high end. The high end can be brought back down by increasing the 22K resistor.

External Inputs. Studios have used the output from their mixing board to trigger a Synare 3. This was accomplished by placing a switching jack in series with the red speaker wire. When no external trigger is plugged in, the normal

MODIFICATIONS.

External Inputs (continued)

Synare 3 speaker acts as an input. When an external input is plugged in, the speaker is disconnected and replaced by the external input. Outputs from mixing boards and microphones have been used to trigger Synare 3s.

TESTER.

A 5 pin, 0.100 inch centers connector is visible on the component side of the board. This connector is used during electrical checkout.

Two of the pins are used to apply the equivalent of battery voltage to the Synare 3. Two pins are used to electronically monitor the regulator outputs. The fifth pin is used to simulate the striking of the playing surface.

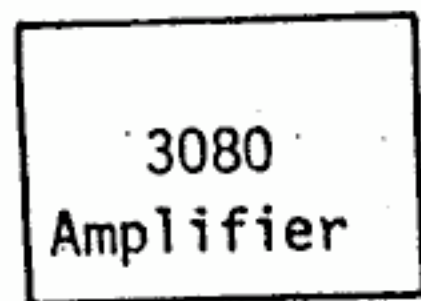

Sketch shows component side.

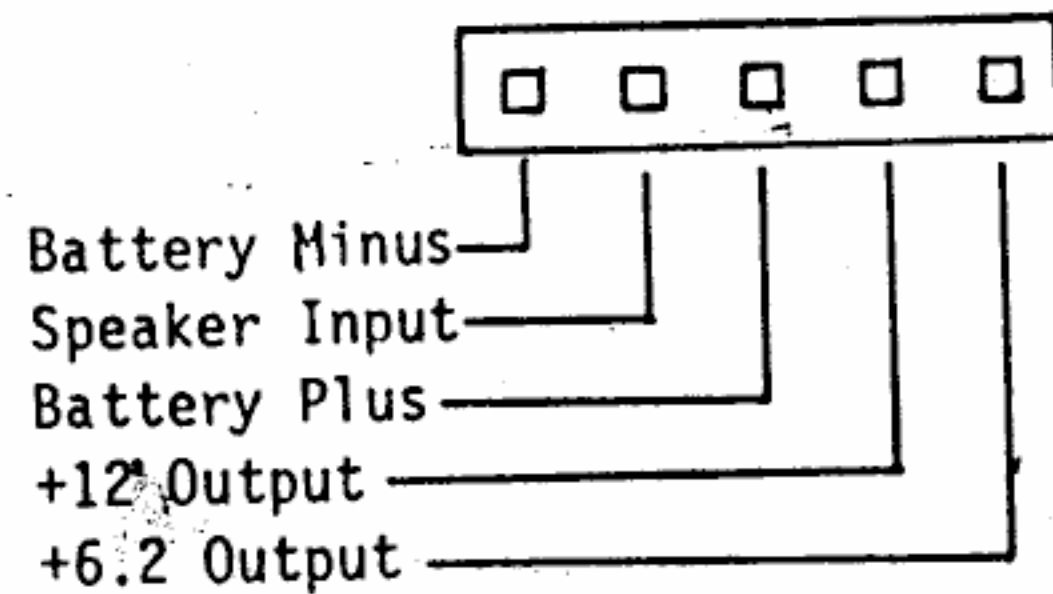

Connector

GENERAL COMPONENT INFORMATION.

Resistors: all resistors are 1/4 watt, 5% carbon film.

Capacitors: all values are listed in microfarads.

Transistors: three different transistors are used and are referred to as 04, 06 and A14. An 04 is a 2N3904; an 06 is a 2N3906. These are general purpose NPN and PNP transistors. The A14 is an MPSA14 which is an NPN darlington.

Integrated Circuits: Eight ICs are used. Five are 3080 transconductance amplifiers available from National or RCA. Two are T0-3 regulators. One is a CMOS 4093BE (only RCA 4093s will work).

Batteries: Alkaline batteries are recommended.

Potentiometers: Three different pots are used. Their values are stamped on their faces. The most common (5) is a 50K; the balance (4) are 1 meg of two different tapers.

Jack: The jack is multifunction. It is used as an output and to switch battery voltage.

Speaker: It is a standard 3 1/2 inch, 8 ohm speaker.

Circuit Layout: The circuits are generally located near their front panel controls. The sketch below shows their general location with respect to the ICs and pots. This sketch does not exactly apply to early serial numbers.

